

Level Best

LASER GRADING BOX

OPERATORS MANUAL

FOR

PARA-LEVEL with *SLOPE-TACH*
ADAPTER

APACHE
CONTROL PANEL
MODEL CB52

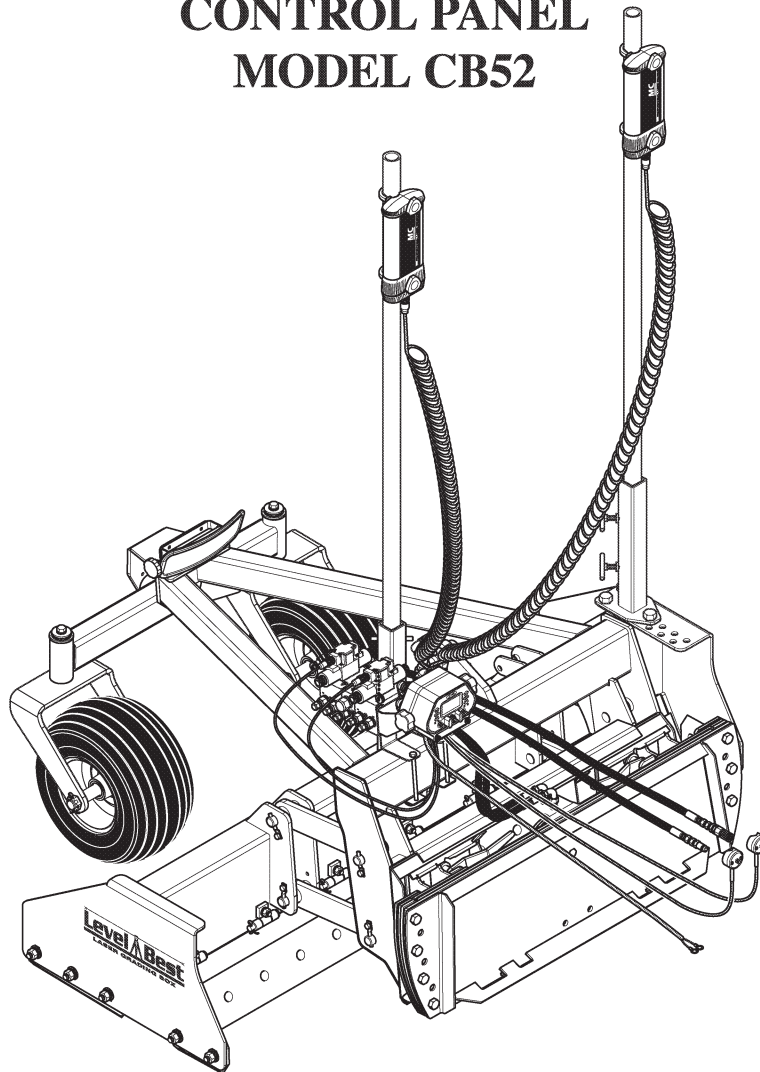

ATI Corporation

New Holland, PA 17557

Phone (717) 354-8721 • FAX (717) 354-2162

1-800-342-0905

www.level-best.com

SEPTEMBER 2007

CAT #LGBPLOM-ACB52-0907

**COPYRIGHT 2007 by
ATI Corporation
New Holland, PA 17557 U.S.A.**

DISCLAIMER

THE INFORMATION IN THIS MANUAL IS PROVIDED TO PROMOTE THE SAFE USE OF, AND ASSIST THE OPERATOR IN ACHIEVING THE BEST PERFORMANCE FROM, THE PRODUCTS DESCRIBED HEREIN WHEN USED FOR THE INTENDED APPLICATION.

MODELS

Part Number	Model Numbers	Description
315-081-000	PL72D	Box, Grader, Para-Level with Slope-Tach, 6', Cylinder Only
315-082-000	PL84D	Box, Grader, Para-Level with Slope-Tach, 7', Cylinder Only
315-083-000	PL96D	Box, Grader, Para-Level with Slope-Tach, 8', Cylinder Only
000-166-475		Kit, Hydraulic, Double, Apache Controls, Includes Valve Assembly, Hoses, Fittings & Solenoid Cable
000-200-188		Kit, Laser Controls, Includes Control Panel, two 360° Sensors, Cables (Power, Sensor & Solenoid) & Remote Switch

NOTE: Optional accessories, Scarifier Assembly, installation and parts manual can be obtained from ATI Corporation or download from web site, www.level-best.com.

TABLE OF CONTENTS

MODELS	ii
TABLE OF CONTENTS	iii
SAFETY INFORMATION	v
Safety Precaution Definitions	v
WARRANTY	vi
LIST OF ILLUSTRATIONS	vii
LIST OF TABLES	viii
SYSTEMS FEATURES AND BASIC OPERATION	1
Purpose	1
Components	1
Control Panel	2
Controls	2
Operation	5
User Setup	7
Rotating Laser	10
Laser Sensor	11
Cables	11
Equipment Setup	14
Job Site Set-Up	16
Set-Up for Level Grading	16
Set-Up for Sloped Grading	16
Benching And Operating	19
Benching	19
Benching with a Rod Eye	20
Operation	20
TROUBLESHOOTING	22
SPECIFICATIONS AND MAINTENANCE	25
Specifications	25
Dimensions	25
Control Panel CB52	25
Laser Sensor BULLSEYE 5MC	25

TABLE OF CONTENTS

Maintenance.....	26
Storage and Transport.....	26
Cleaning.....	26
Cables and Hoses.....	26
Machine	26
Calibration	26
Service	26
NOTES.....	28
REGISTRATION CARD.....	29

SAFETY INFORMATION

This manual is furnished to you, the owner/operator, as a guide to get the greatest benefit from your Grading Box. ATI Corporation wants you to be able to get the most use out of your Grading Box through safe and efficient operation.

Before attempting to operate the Grading Box, carefully read all sections of this manual. Be sure that you thoroughly understand all of the safety information and operating procedures.

SAFETY PRECAUTION DEFINITIONS

Dangers, Warnings, Cautions, and Notes are strategically placed throughout this manual to further emphasize the importance of personal safety, qualifications of operating personnel, and proper use of the grading box in its intended application. These precautions supplement and/or complement the safety information decals affixed to the unit and include headings that are defined as follows:

DANGER

Indicates an imminently hazardous situation which, if not avoided, will result in death or serious injury.

WARNING

Indicates a potentially hazardous situation or practice which, if not avoided, could result in death or serious injury.

CAUTION

Indicates a potentially hazardous situation or practice which, if not avoided, will result in damage to equipment and/or minor injury.

NOTE: Indicates an operating procedure, practice, etc., or portion thereof, which is essential to highlight.

- Always use caution and safe operating practices when operating this equipment.
- Always set the Automatic/Manual Switch on the Control Panel to MANUAL before leaving the operator's seat or whenever the machine is not moving.

- Always allow for clearance under the cutting edge of the machine when tuning the system or when switching to automatic control. Insufficient clearance could cause the machine to lift itself off the ground as its cutting edge attempts to achieve the programmed slope.
- Never adjust the position of the Laser Sensor when the system is in automatic control.
- Never perform service work on your machine or the Automatic Control System when the system is in automatic control.
- Install all safety panels and guards before operating your equipment.
- Stay clear of all moving parts when the machine is in operation.
- Keep all people clear of the machine when it is running.
- Keep feet and other body parts from under the cutting edges of the machine at all times.
- Read and comply with all safety recommendations of your Tractor/Skid Steer manufacturer, as outlined in its operator and service manuals.

NOTE: References made to left, right, front, and rear are those directions viewed from behind the power unit and grading box.

NOTE: Some equipment depicted in illustrations may not reflect exact production model configurations.

NOTE: All safety, operating, and servicing information reflects current production models at the time of publication of this manual.

NOTE: ATI Corporation reserves the right to discontinue models at any time, change specifications, and improve design without notice and without incurring obligation on goods previously purchased and to discontinue supplying any part listed, when the demand does not warrant production.

WARRANTY

This Laser Grading Box is designed and manufactured to high quality standards. ATI Corporation, therefore, guarantees this Laser Grading Box to be free from defect in workmanship and materials for one (1) year from purchase date. If the machine is used for rental purposes, the warranty is limited to ninety (90) days.

Laser Controls, Vended Components and Control Valve Parts are warranted separately by their respective manufacturers.

Does not cover normal wear or failure due to hydraulic oil contamination.

Misuse, abuse, misapplication, and unauthorized alterations will void this warranty.

LIST OF ILLUSTRATIONS

Figure 1. Plane of Laser Light with Components of the Automatic Control System	1
Figure 2. Front View of the Control Panel.....	3
Figure 3. Rear View of the Control Panel.....	4
Figure 4. Control Panel Display.....	4
Figure 5. Sensor Position Indicator.....	4
Figure 6. LED Grade Display	5
Figure 7. User Setup Display Screen	7
Figure 8. LCD Brightness and Contrast Edit Mode.....	8
Figure 9. Deadband Edit Mode.....	8
Figure 10. Valve Speed Edit Mode	8
Figure 11. Reference Elevation Edit Mode.....	9
Figure 12. Units of Measure Edit Mode	9
Figure 13. Store and Recall Edit Mode.....	9
Figure 14. Rotating Laser	10
Figure 15. Bullseye 5MC.....	11
Figure 16. Power Cable.....	12
Figure 17. Sensor Junction Cable	12
Figure 18. Sensor Cable.....	12
Figure 19. Valve Cable.....	13
Figure 20. Remote Switches Cable.....	13
Figure 21. Control Panel Mounting	14
Figure 22. Components of the Automatic Control System on a Skid Steer.....	15
Figure 23. Remote Switch Mounting	15
Figure 24. Junction Block and Laser Sensor Cables.....	16
Figure 25. Method One: Align Rotating Laser with Grade Stakes.....	17
Figure 26. Sight Over Rotating Laser.....	17
Figure 27. Grade Stake with Elevation Mark	17
Figure 28. Method Two: Align Rotating Laser with Grade Stakes.....	18
Figure 29. Benching the Para-Level LGB with a Level Plane	19
Figure 30. Lube and Maintenance Chart.....	27

LIST OF TABLES

Table 1. Units	9
----------------------	---

SYSTEMS FEATURES AND BASIC OPERATION

PURPOSE

The Level Best Laser Grading Box (LGB) is a cost-efficient method for fine grading. Various capacities sized to fit the skid steer or tractor with a choice of automatic control systems are available. This manual is for skid steer systems equipped with an Apache Technologies, Inc. CB52 Automatic Control System.

Laser-guided depth control provides unmatched measurement of plane from a single reference point. Grade information from a rotating laser is processed and automatically directs the grading box's hydraulics to maintain the elevation of the cutting edge.

When used in conjunction with a Slope-Tach adapter, the Para-Level LGB also provides side-to-side grading which is often difficult when using a skid steer loader.

The Grade Position LEDs on the Laser Sensor indicate the location of the box's cutting edge relative to the required finished grade (The Control Panel has a set of LEDs that mimic the Laser Sensor's LEDs).

- In manual control, the operator watches the Grade Position LEDs and uses the controls to keep the center LEDs lit, thereby keeping the box "On Grade".
- In automatic control, the Automatic Control System controls the box's hydraulic cylinder to keep the center LEDs lit, thereby keeping the box "On Grade".

- The control system used with the Slope-Tach adapter uses two laser sensors. One laser sensor provides grade information for the center elevation of the LGB, the second laser sensor ensures the proper tilt angle is maintained by measuring the elevation at one end of the LGB.

COMPONENTS

The control system consists of 4 components:

Rotating Laser – Provides a reference Plane of Laser Light over the job site (refer to Figure 1). The light plane may be level or set at an angle to match the slope of the ground.

Laser Sensors – Mounted at a specific height on a mast on the Laser Grading Box, it determines the difference in depth based on the Plane of Laser Light. When used with the Slope-Tach adapter, two laser sensors are required.

NOTE: Apache Technologies has available several Laser Sensor models that function with the CB52 Control Panel. This manual covers the BULLSEYE 5MC only although other BULLSEYE models may be used.

Control Panel – Mounted on the Grading Box, the Control Panel processes data received from the Laser Sensors and from the operator. LEDs indicate the location of the box's cutting edge relative to the desired finish grade. When set to Automatic, it provides signals to the Valve Assembly to either extend or retract the cylinders on the Laser Grading Box or Slope-Tach adapter.

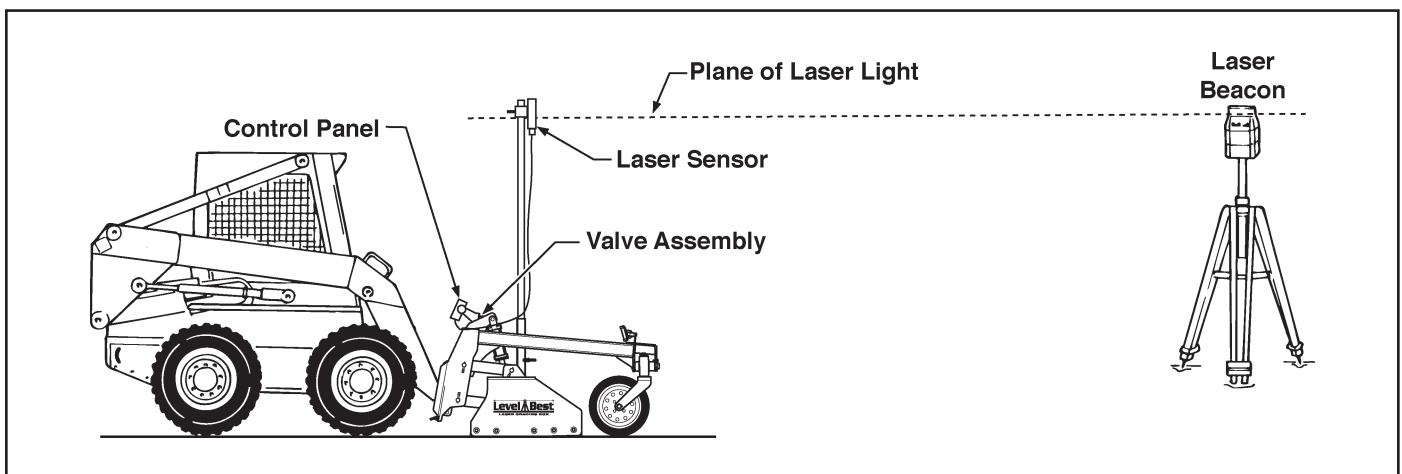

Figure 1. Plane of Laser Light with Components of the Automatic Control System

SYSTEMS FEATURES AND BASIC OPERATION

Valve Assembly – Wired to the Control Panel, the valve meters hydraulic oil to the hydraulic cylinders for elevation and tilt control.

In addition, wires and cables to connect the components are included with the unit. Two remote switches provide control from within the skid steer loader's operator station while maintaining visible contact of the Control Panel screen mounted on the LGB.

CONTROL PANEL

The Control Panel is essentially a computer with built-in logic for the inputs and outputs connected to it. The Control Panel provides many adjustments to allow compatibility with different machinery and application requirements.

The Control Panel uses an LCD screen to provide information to the operator. One side of the screen displays elevation, or blade depth, at the center of the LGB and other side is for elevation at the right-side of the blade.

Selections are made via two multiple-function switches (joysticks) that move up or down and left or right, can be rotated in either direction, and pressed. Between each joystick and the power switch is a support, or hand rest, to help steady the operator's hand as he moves the controls. Grade LEDs are used to indicate direction of grade.

The laser sensor, located at the right side of the LGB, controls the tilt, or slope, of the cutting edge by measuring elevation of the grade at a different location than the center laser sensor.

NOTE: This manual references the Para-Level's ability to follow slope. This does not imply that a slope laser sensor is required to provide this functionality. The tilt capability is obtained by measuring elevation at two different positions relative to the rotating laser.

The Control Panel has two modes accessible to the user; Operation and User Setup. In User Setup mode, items such as valve speed and LCD brightness can be adjusted. Operation mode allows operation of the Para-Level LGB either automati-

cally, with the Control Panel controlling depth and tilt, or manually, with the operator controlling the blade depth and tilt.

NOTE: The CB52 Control Panel can be configured several different ways. This manual assumes the ATI factory default setting displaying the center laser sensor data, or elevation, on the left side of the LCD and right-side laser sensor data, or tilt, on the right side of the LCD. Apache Technologies references this as dual elevation mode because both laser sensors reference elevation and the LCD displays elevation data.

Controls

Two remote switches are mounted inside the skid steer loader's operator station with the cables downward. These two switches mimic the joystick controls located on the CB52 Control Panel for operation of the raise, lower, and tilt functions and selection of automatic or manual control. Refer to the section on Equipment Setup for more information regarding proper installation of the remote switches.

NOTE: This manual refers only to the joysticks on the control panel. Any action or motion required by the joysticks can be assumed to cause the same function/reaction when using the remote switches, provided the remote switches have been mounted in the correct orientation.

The following identifies the indicators, switches and type of switch on the Control Panel.

SYSTEMS FEATURES AND BASIC OPERATION

Front Control Panel Switches

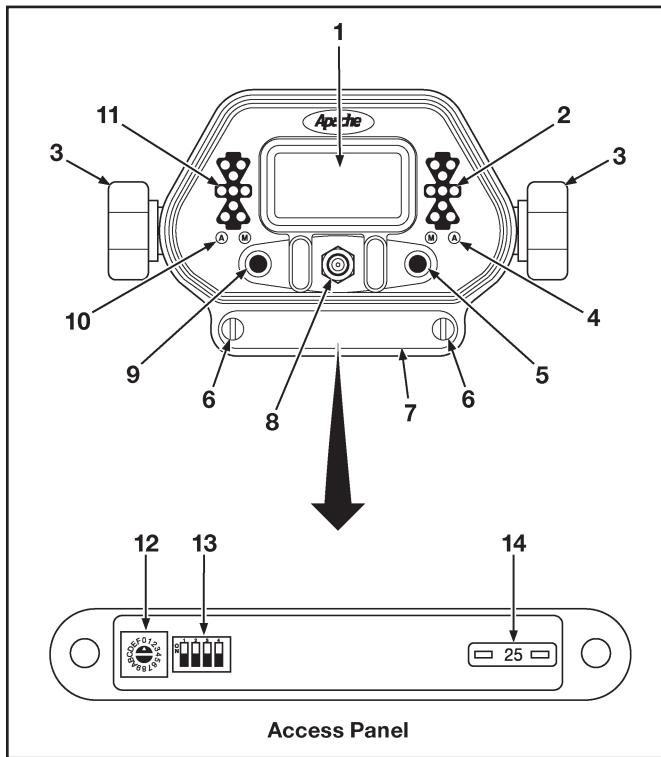

Figure 2. Front View of the Control Panel

LCD Display (1) – indicates the various operation and configuration modes. The items displayed change based on the mode and User Setup parameters chosen. Refer to the section on LCD display for more specific information.

LED Grade Display for Tilt Function (2) – indicates where the cutting edge is in relation to the on-grade position. Refer to the section on Grade Indicators for more information.

Mounting Knobs (3) – secures the control panel to the mounting brackets on the Para-Level Laser Grading Box.

Auto/Manual LED for Tilt (4) – green “A” LED illuminates when in Automatic operation and amber “M” LED illuminates when in Manual operation.

Tilt Joystick (5) – left/right movement selects Auto/Manual control for the slope function and up/down movement tilts the blade. Rotation increases/decreases the control setpoint. Pressing “in” enables elevation and slope matching. When released, the joystick returns to a center, neutral position.

This joystick also navigates through the User Setup menus.

Access Panel Screws (6) – Retains access panel to the Control Panel.

Access Panel (7) – Panel contains a fuse, rotary switch and DIP switch used in factory setups.

Power Switch (8) – Turns power on and off. Also provides access to Help screens by pressing up while operating.

Elevation Joystick (9) – left/right movement selects Auto/Manual control for the elevation function and up/down movement raises and lowers the blade. Rotation increases/decreases the control setpoint. Pressing “in” enables elevation and slope matching. When released, the joystick returns to a center, neutral position.

This joystick also navigates through the User Setup menus.

Auto/Manual LED for Elevation (10) – green “A” LED illuminates when in Automatic operation and amber “M” LED illuminates when in Manual operation.

LED Grade Display for Elevation Function (11) – indicates where the cutting edge is in relation to the on-grade position. Refer to the section on Grade Indicators for more information.

CAUTION

Do not change or modify the Rotary or DIP switch positions. These switches are set at the factory before shipment. Contact the installation technician for additional information, if required.

Rotary Switch (12) – Used for factory setup. Do not adjust this unless directed to by ATI Corporation service department.

DIP Switch (13) – Used for factory setup. Do not adjust this unless directed to by ATI Corporation service department.

Fuse (14) – Automotive-style, 25 amp fuse protects against power surges.

SYSTEMS FEATURES AND BASIC OPERATION

Rear Control Panel Connections

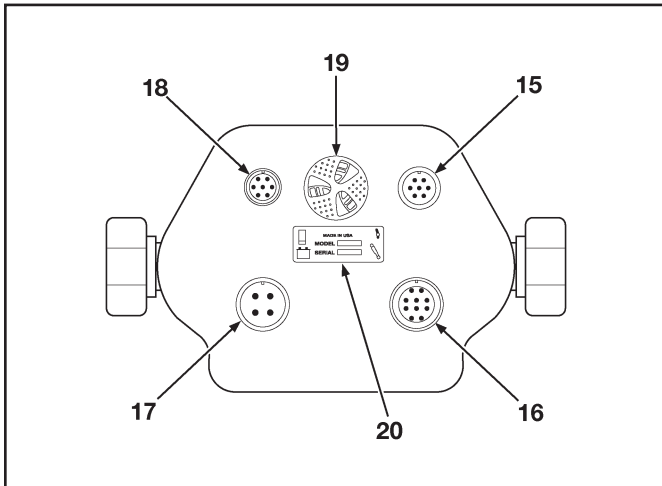

Figure 3. Rear View of the Control Panel

Remote Switch (15) – 7-pin connector for the remote switch wire harness.

Hydraulic Valve Output (16) – 10-pin connector for the valve wire harness.

Machine Power Input (17) – 4-pin connector for the power wire harness.

Laser Sensor (18) – 7-pin connector for laser sensor input. This connects to the junction box.

Beeper (19) – beeper for audible indication of alarms and switch engagement. A single beep is activated when a switch command is accepted. A double beep is activated when a selected function is not available or is incorrect. Beeper volume can be adjusted by rotating the beeper.

Serial Number Plate (20) – records build and model data for troubleshooting purposes.

Control Panel Display

The Control Panel Display provides information to the operator for efficient control of the LGB in either Automatic or Manual control. Inputs from the joystick located on the left side are displayed on the left side of the screen and vice-versa.

The default ATI Corporation setup of the Para-Level with Slope-Tach control system displays data as two different elevations. Elevation information for the center laser sensor is shown on the left side

of the Control Panel LCD and elevation information for the right laser sensor is shown on the right side of the LCD.

NOTE: The right laser sensor is sometimes referred to as a slope or tilt sensor because it controls the Slope-Tach hydraulic cylinder which allows the Para-Level LGB to create a sloped grade. However, actual data is based on elevation, not slope.

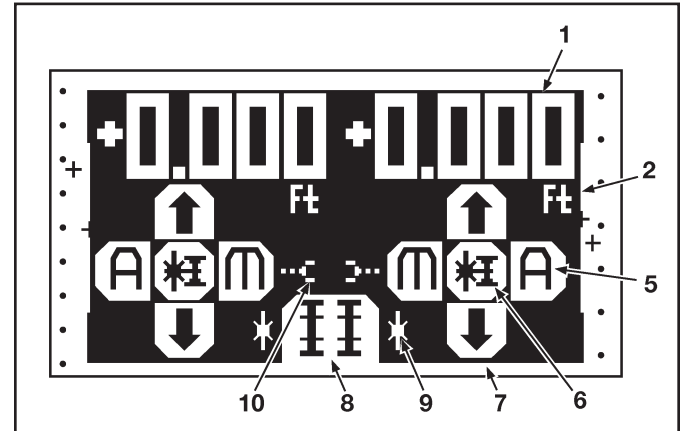

Figure 4. Control Panel Display

Reference Elevation (1) – indicates the reference elevation. The value is referenced from the last bench mark.

Units (2) – displays the units of the reference elevation. Can be changed in User Setup mode.

Sensor Position Indicator (3) – indicates the elevation relative to the vertical reception range of the receiver. The + indicator blinks when reception is lost.

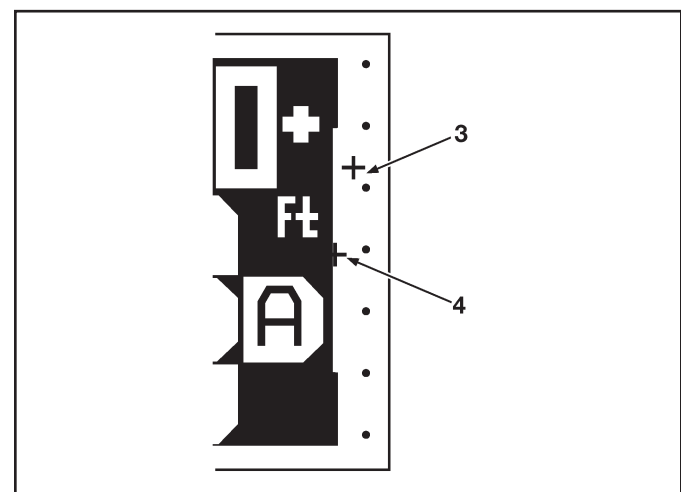

Figure 5. Sensor Position Indicator

SYSTEMS FEATURES AND BASIC OPERATION

The on-grade set range will vary depending on the width of the deadband. The smaller the deadband, the larger the range. The larger the deadband, the smaller the range.

Control Setpoint (4) – indicates where on-grade is set relative to the vertical reception range.

Automatic/Manual Indicator (5) – indicates if the control system is in manual (M) or automatic (A) mode.

Joystick Function Icon (6) – indicates the current mode of the joystick. Pressing the joystick alternates control between slope matching/benching and slope control setpoint.

Raise/Lower Indicator (7) – indicates the direction of movement of the blade.

Operating Mode Indicator (8) – indicates the operating mode of each side of the Control Panel. Dual elevation control is shown.

Control Source Indicator (9) – indicates the source of control. Starburst icon indicates input is being received from a laser receiver.

Linked/Unlinked Elevation Mode (10) – only used in dual elevation mode.

Grade Indicators

On each side of the LCD is a grade indicator. The grade indicator is a set of red and green LEDs that indicate relative position to grade. When a laser is striking the sensor, there are 5 possible positions of grade information indicated.

High Coarse - 3 top red LED's forming down arrow.

High Fine - 3 top red LED's and 3 green on-grade LED's.

On-Grade - 3 green LED's forming horizontal bar.

Low Fine - 3 bottom red LED's and 3 green on grade LED's.

Low Coarse - 3 bottom red LED's forming up arrow.

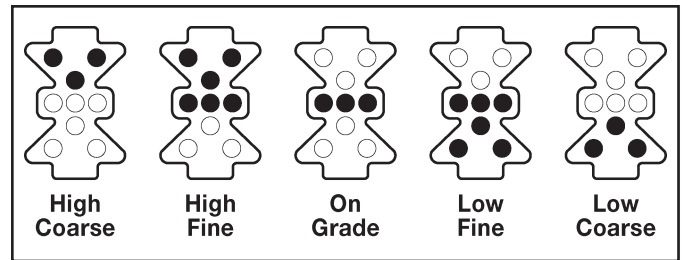

Figure 6. LED Grade Display

If the laser moves off the reception range of the sensor, an out-of-beam will be indicated on the LEDs. If the last laser reception was on the bottom of the sensor, the top 3 LEDs will flash indicating to move the sensor down. If the last laser reception was on the top, the bottom 3 LEDs will flash indicating to move the sensor up. The out-of-beam indication lasts for 2 minutes.

Operation

Control of the Para-Level Laser Grading Box is accomplished through the Control Panel. The operator places the system in either Automatic control, where the system raises/lower/tilts the LGB based on inputs from the laser system, or Manually, where the operator moves the LGB using the controls on the Control Panel (or remote switches).

WARNING

Always turn the system to manual before leaving the skid steer loader. Move both joysticks toward the middle (inward) to activate manual mode.

To turn the system on, toggle the Power switch to the I (on) position. The LEDs and LCD will light to confirm power. The Control Panel will perform a diagnostic check to ensure the system components are present and responding correctly. If the laser sensors are present, the LEDs on the sensors will light as a system check. If components are not found, a “No Sensors Found” message is displayed.

NOTE: The system must be restarted if sensors or components are connected/added.

SYSTEMS FEATURES AND BASIC OPERATION

Automatic/Manual Control



To place the Para-Level LGB under Automatic control, move the left joystick to the left (outward) and the right joystick to the right (outward) and release each to neutral. The green “A” LEDs on the Control Panel will light to indicate Automatic control.

Under Automatic control, the Control Panel sends the appropriate signals to the valve to raise/lower/tilt the LGB to obtain and maintain an on-grade position. If the sensor is outside the range of the laser signal, it must be moved within range to start receiving signals.

To place the Para-Level LGB under Manual control, move the left joystick to the right (inward) and the right joystick to the left (inward) and release each to neutral. The amber “M” LEDs on the Control Panel will light to indicate Manual control.

Under Manual control, the LED Grade Display will indicate grade information but will not send adjustment signals to the valve. Adjustment of the LGB elevation and slope can be accomplished manually.

Raise/Lower



The left-side joystick raises or lowers the LGB when under Manual control. Move the joystick up to raise the blade and down to lower the blade.

When under Automatic control, the left-side joystick will temporarily raise or lower the LGB. When the joystick is released, the LGB returns to Automatic control.

Tilt

The right-side joystick adjusts the slope angle of the LGB when under Manual control. When under Automatic control, the right-side joystick will temporarily change the slope angle of the LGB. When the joystick is released, the LGB returns to Automatic control.

Elevation/Slope Offset (Reference Adjustment)



The CB52 has the capability to adjust the on-grade point without adjusting the laser sensor(s) to within one inch of the end of its range. This feature can be used to raise the grade for initial rough-cut and then return the LGB to desired grade for finishing.

The on-grade reference point is adjusted from the Control Panel by rotating the appropriate joystick. Rotate the joystick clockwise increases the elevation, counterclockwise decreases the elevation. The offset will not go beyond a limit programmed into the laser sensor.

When the reference is adjusted, the LCD displays the actual elevation change from the benchmark.

If linking is enabled, either joystick can be rotated and the on-grade reference is adjusted equally for both elevation and tilt. When under Automatic control, the LGB will begin to move immediately. When under Manual control, the blade will not move until placed under Automatic control.

Elevation/Slope Matching



Elevation/Slope matching allows the current laser signal to be temporarily set to the on-grade reference. This allows adjustment of the on-grade elevation for an initial cut of the area to be graded at a set distance above the engineered plane.

When the laser strike signal is within range of the laser sensor and at least one inch from the outer limit, press and hold the appropriate joystick for approximately 1 second and release when a single beep is heard from the Control Panel. The LCD and grade LEDs will indicate the LGB is on-grade. If outside the acceptable laser sensor range, two beeps are sounded to indicate the command was not accepted.

SYSTEMS FEATURES AND BASIC OPERATION

To reset the elevation to the default center on-grade position, press and hold the joystick for five seconds. The first beep is heard at approximately one second and the second beep is heard at 5 seconds, when the elevation is reset to the default. The elevation control setpoint returns to the center position and the LCD indicates the elevation in relation to the default.

Link

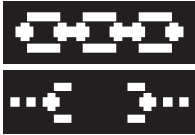

The Link capability within the Control Panel allows the two different elevations of the LGB to be adjusted/moved simultaneously. When activated, this function applies to changing Automatic/Manual control, adjusting elevation offset, and adjusting or resetting the elevation matching features.

Before linking, set the LGB in the desired position to ensure the relative positioning of the two laser sensors. This is usually parallel to the laser plane. With the Control Panel in dual elevation mode (default), move both joysticks inward (manual position) and hold for 3 seconds. The link icon on the LCD will change from a broken link to a connected link (chain).

Audio Alerts

The beeper on the back of the Control Panel can be rotated to adjust the volume of the tones emitted.

A single, short beep is sounded to indicate an input, or command, is accepted. A double beep indicates a command was not accepted. A triple beep is sounded when the Control Panel is first powered up.

User Setup

When purchased from ATI Corporation with the Para-Level, the control system is setup specifically for the unit purchased. Some items may be customized to suit the operator's specific needs or operating conditions. Up to three separate configurations can be saved. A fourth configuration returns the unit to the factory default settings

To access the User Setup screen, hold the Power switch in the UP position for 1 second. When the

setup screen appears on the display, release the switch. The Control System automatically enters manual mode when the User Setup screen is accessed.

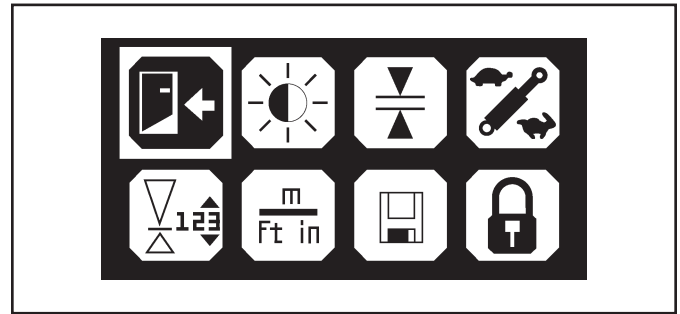

Figure 7. User Setup Display Screen

The User Setup screen has eight icons. The various icons and setup functions are accessed via either the joystick, rotating or moving the switch until the desired function is highlighted. Press either joystick to enter the selected function.



To return to the Operation screen, highlight the Return icon and press either joystick.

NOTE: Help screens are available within each function. Hold the power switch in the up position to access the help screen.

LCD Brightness and Contrast



Using the joysticks, highlight the LCD icon and press a joystick to enter the Brightness and Contrast edit mode. When in edit mode:

The left side indicates the brightness level and ranges from 5 to 100. Rotate the left-side joystick clockwise to increase the brightness level and counterclockwise to reduce the brightness level. Changes are made in increments of 5.

The right side indicates the contrast level and ranges from 0 to 100. Rotate the right-side joystick clockwise to increase the contrast and counterclockwise to reduce the contrast. Changes are made in increments of 1.

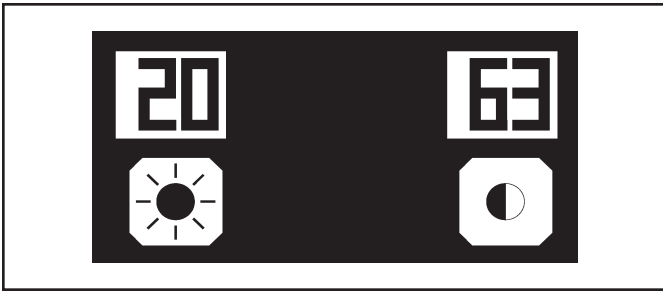

Figure 8. LCD Brightness and Contrast Edit Mode

Deadband (Accuracy)



Deadband refers to how tight a tolerance, or accuracy, is desired. Although a greater accuracy is normally desired, if the system becomes unstable, overreacting between above grade and below grade, the deadband should be increased to minimize overreaction.

Using the joysticks, highlight the deadband icon. Press a joystick to enter the Deadband edit mode.

When in edit mode, the left side of the LCD displays the elevation deadband in ft. The maximum elevation deadband is 0.170 ft. (2.00 in.). Rotating the left-side joystick changes the deadband for the elevation.

CAUTION

Setting the Deadband too narrow may cause the Grading Box to become unstable. If this happens, increase the deadband or decrease the gain setting.

NOTE: Adjustment is for display deadband. Default control deadband is the same but may be set smaller during installation.

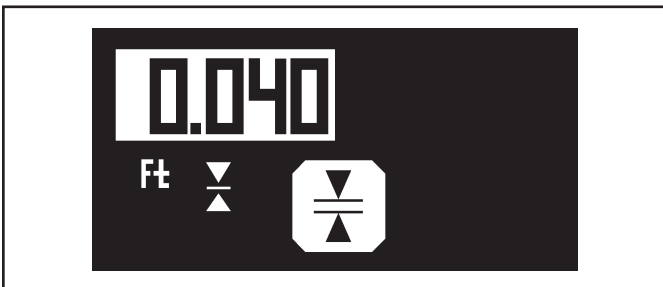

Figure 9. Deadband Edit Mode

Valve Speed



Valve speed relates to gain, or the speed at which the control system adjusts the Para-Level. When operating in sandy or loose materials, decrease the valve speed for slower hydraulic speed. When operating in clay, dirt or tighter materials, increase the valve speed for a faster hydraulic speed. If the system becomes unstable, overreacting between above grade and below grade, decrease the valve speed.

Using the joysticks, highlight the valve speed icon. Press the joystick to enter the valve speed edit mode. When in edit mode a single number appears, indicating the valve speed as a percentage between 0 and 100%.

Rotate either joystick to adjust the valve speed. The factory default is 50%.

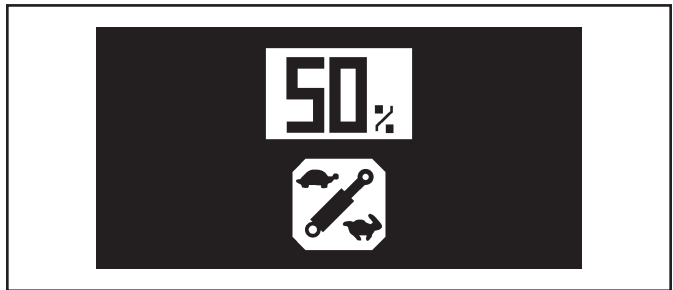

Figure 10. Valve Speed Edit Mode

Reference Elevation



This sets a reference elevation, displayed on the edge of the operation mode display. Only the elevation (left side) can be adjusted.

Using the joysticks, highlight the reference elevation icon. Press the joystick to enter the reference elevation edit mode. When in edit mode a single number appears on the left side of the display indicating the overall range of the display in operating mode. The units shown reflect the units selected.

Rotate the left-side joystick to adjust the range.

SYSTEMS FEATURES AND BASIC OPERATION

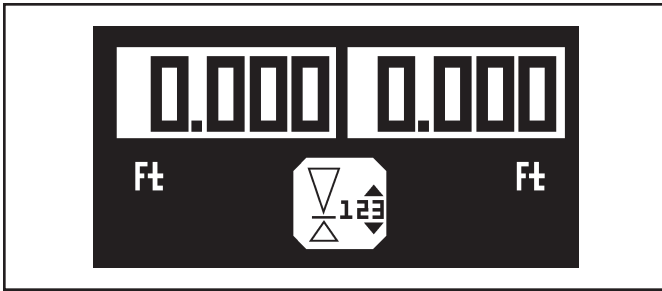

Figure 11. Reference Elevation Edit Mode

Units of Measure



The units used to display information to the operator can be changed.

Using the joysticks, highlight the units of measure icon. Press the joystick to enter the edit mode. When in edit mode, the currently selected units appear.

To adjust the elevation units, displayed on the left side of the screen, rotate the left-side joystick.

To adjust the slope units, displayed on the right side of the screen, rotate the right-side joystick.

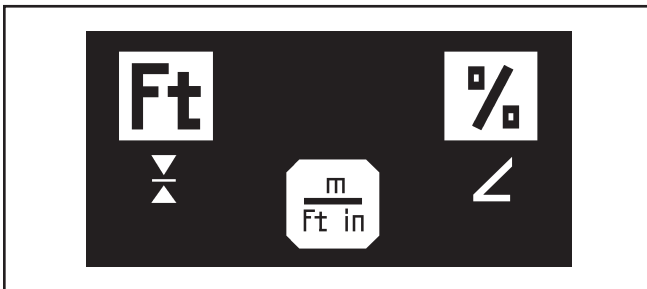

Figure 12. Units of Measure Edit Mode

The available units are shown in Table 1.

Table 1. Units

Elevation		Slope	
Display	Units	Display	Units
Ft	feet	%	Percentage of slope
in	inches	°	Degrees of slope
m	meters		

Store and Recall Setup



This allows the operator to store three different setup configurations for future recall.

Using the joysticks, highlight the store and recall configuration icon. Press the joystick to enter the edit mode. When in edit mode, the left-side display and joystick manages the store function and the right-side display and joystick manages the recall function. Checksum values are also displayed to check copied setups.

To store the current configuration, rotate the left-side joystick to the desired number on the display. When selected, press the joystick to store the setup configuration. A message appears asking "Do you want to store?" Select YES to store and NO to return to the previous menu.

When YES is selected, a new name can be entered. Rotate the left-side joystick to scroll through the character choices. Move the joystick to the right to move to the next character. Up to 7 characters may be entered. Once entered, the named setting appears on the store and recall screen for future selection.

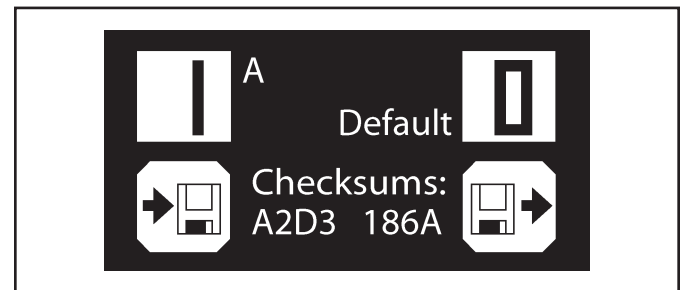

Figure 13. Store and Recall Edit Mode

To recall a saved configuration, rotate the right-side joystick to scroll through the selections. Highlight the desired configuration and press the right-side joystick to select it. A message appears asking "Do you want to recall the setup?" Select YES to recall and make the stored configuration the current configuration. Select NO to return to the previous menu.

Lock Setup



The current settings can be locked so changes to certain settings cannot be made without unlocking.



Using the joysticks, highlight the lock icon. Press the joystick to lock the configuration. The icon changes to indicate it is locked.

When locked, the following settings cannot be changed:

- deadband
- valve speed
- elevation and slope matching reference
- elevation values
- units of measure
- store and recall settings
- link sides

If changes are attempted to these settings, a "Locked" message appears on the screen.

ROTATING LASER

The Automatic Control System can operate with many models of Rotating Lasers. The laser must have a 360° rotating head with invisible or red beam and a speed of 8-40 RPS (revolutions per second). The faster the laser's speed the more optimally the system will perform.

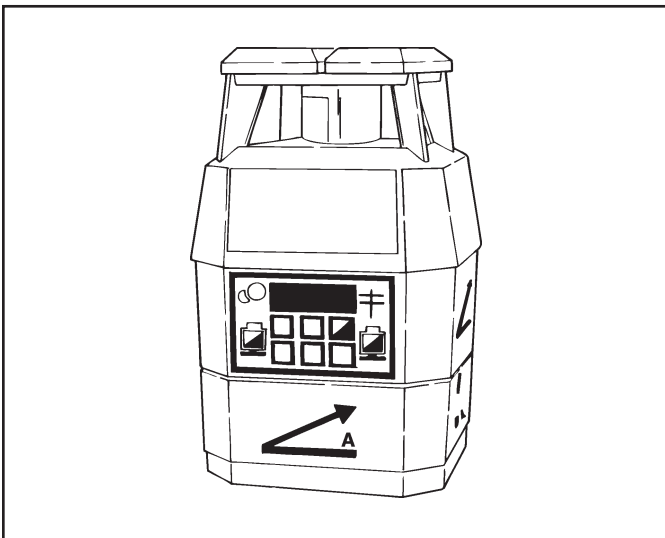

Figure 14. Rotating Laser

The Rotating Laser is mounted on a tripod, which is located on the job site near where the box is operating. The Rotating Laser is the unit that creates the plane of laser light detected by the Laser Sensor.

The Rotating Laser transmits a focused plane of laser light approximately 1000 feet (300 meters), optimal range for most Rotating Lasers, as it rotates.

Rotating Lasers are available in single grade, dual grade, and steep slope versions. They can be quickly and easily aligned to job site requirements without complicated calculation of angles.

A dual slope Rotating Laser can be configured for level, single slope, or dual slope applications. Simply enter the required percent of grade and align the Rotating Laser to the axis (direction) to be graded.

- Percent of Grade. The change in elevation for every 100 feet (30 meters) graded.
- Slope. The change in elevation per foot (meter).

WARNING

Never look directly into a laser light or serious injury to the eye may occur. In general, incidental exposure of the laser to the eye will not do damage. However, avoid looking into the beam whenever possible. Use a target for viewing the laser spot.

WARNING

Use of any laser on a worksite is controlled by OSHA regulations found at 29 CFR 1926.54. Be familiar with these regulations before using any laser beacon used in conjunction with this system. Review and understand all literature provided with the Laser System before operating.

WARNING

Laser protection devices must be provided to all workers in the area if the laser system exceeds five (5) milliwatts. Refer to the literature provided with the system to determine the power output. If unsure of the strength of the laser system, anti-laser eye protection should be provided to all workers.

SYSTEMS FEATURES AND BASIC OPERATION

LASER SENSOR

The Apache BULLSEYE 5MC laser sensor is a rugged, 360° electronic sensor that detects laser light generated by rotating lasers. The unit is designed to work with all common rotating laser beacons and detects both visible and invisible beams.

The sensor does not have any on-board switches, All settings are made on the Control Panel. Power to the BULLSEYE 5MC sensor also comes from the Control Panel. A small, built-in LED display provides grade elevation position, plus high and low lost beam indication.

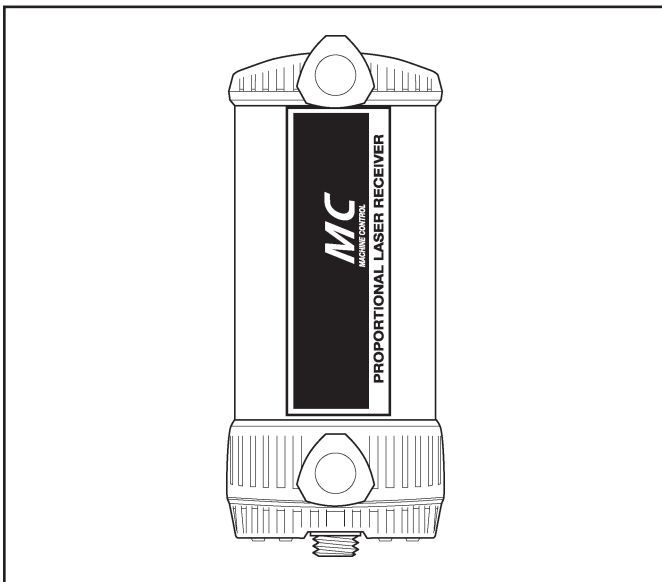

Figure 15. Bullseye 5MC

Two Laser Sensors are mounted on mast poles above the cutting edge of the box. An elevation sensor is mounted in the center and the tilt or slope sensor is mounted on the right side of the LGB. The sensors detect the plane of laser light produced by the Rotating Laser. The Laser Sensors provide grade information to the Control Panel based on the location of the plane of laser light. The Control Panel then has the valve assembly drive the Grading Box's hydraulics accordingly.

CABLES

The cables are provided to connect the various components together into a system. Each connector uses a unique number of pins to prevent the components from being connected incorrectly. At the Control Panel, each cable uses a press-and-twist style of connector. After the cable is pressed into the socket, twist the ring clockwise until tight to secure it.

⚠ CAUTION

Never force a connector into a socket.

⚠ CAUTION

All cables must be secured with adequate cable length to avoid pinching, stretching and tight bending. Do not clamp cables to pipes or hoses that may generate high heat.

Cable Configurations

Power Cable - supplies power to the system.

NOTE: The Control Panel supports both 12 and 24-volt machine systems. However, the valve is 12 volts only. Contact ATI Corporation for additional information when using a 24-volt system.

Junction Block/Receiver Cable - provides a connection method for two sensor cables and the one connector on the Control Panel. The junction block end of the cable attaches to the Control Panel mounting bracket.

Information from each laser sensor is coded to identify the sensor and, when the information is received, the Control Panel decodes the signals. This allows the signals to be passed to the Control Panel through a single connector.

Sensor Cables (2) - power the sensor and communicate grade information between each Laser Sensor and the Control Panel. The 90° connector attaches to the junction block end of the receiver cable and the straight end to the Laser Sensor(s). These are coiled cables that can hang freely between the Control Panel and Laser Sensor mounted on the mast.

SYSTEMS FEATURES AND BASIC OPERATION

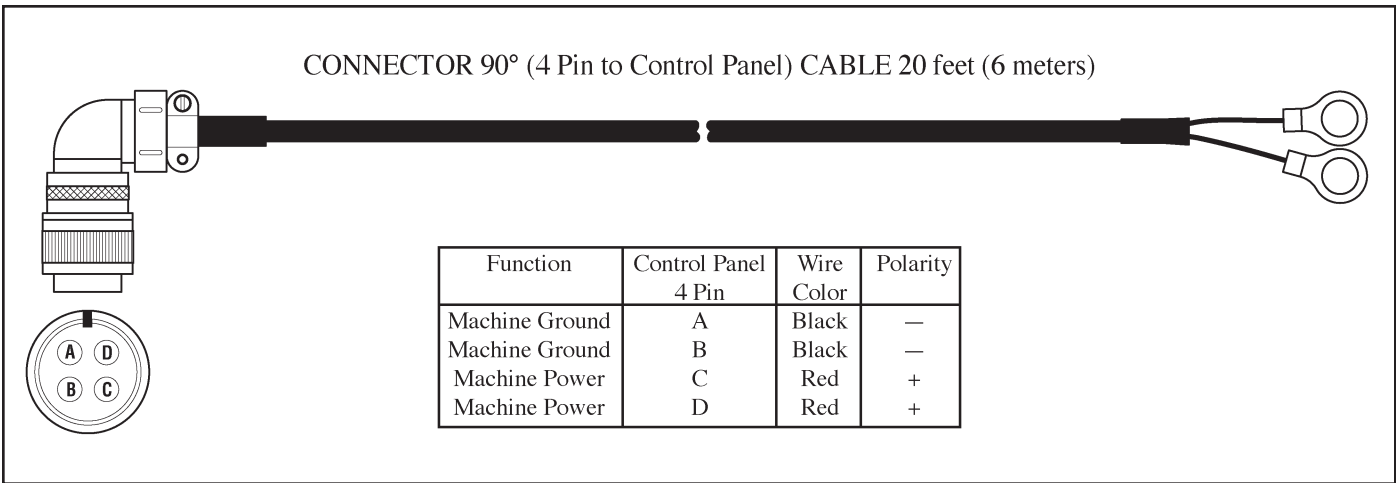

Figure 16. Power Cable

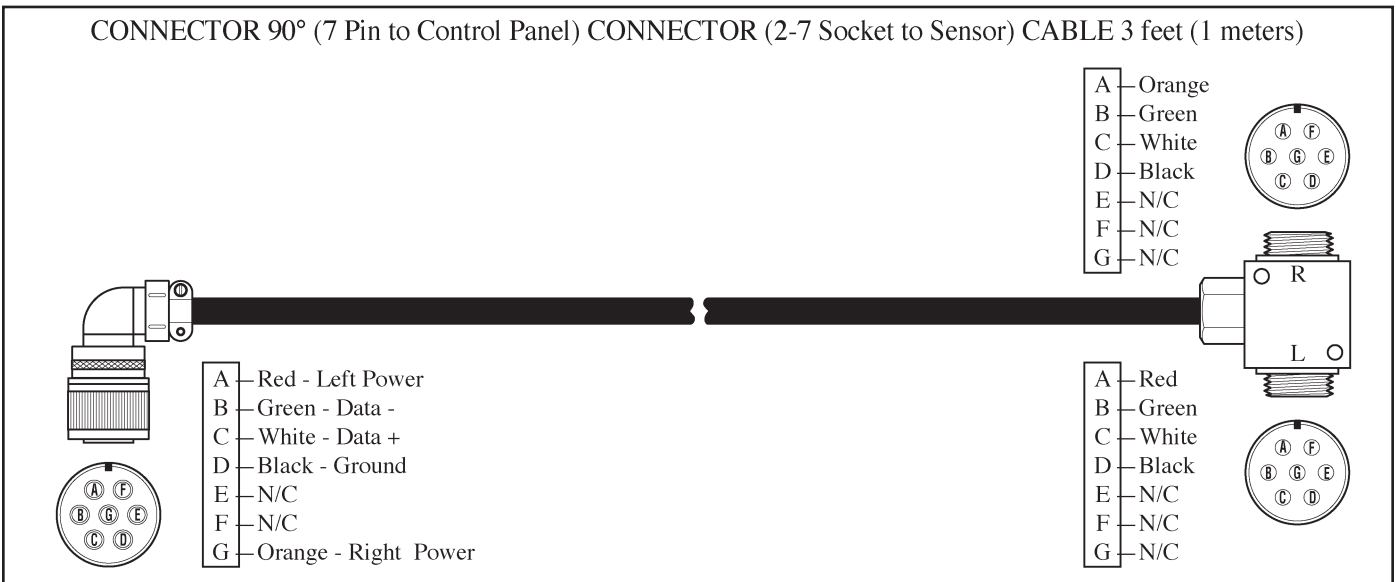

Figure 17. Sensor Junction Cable

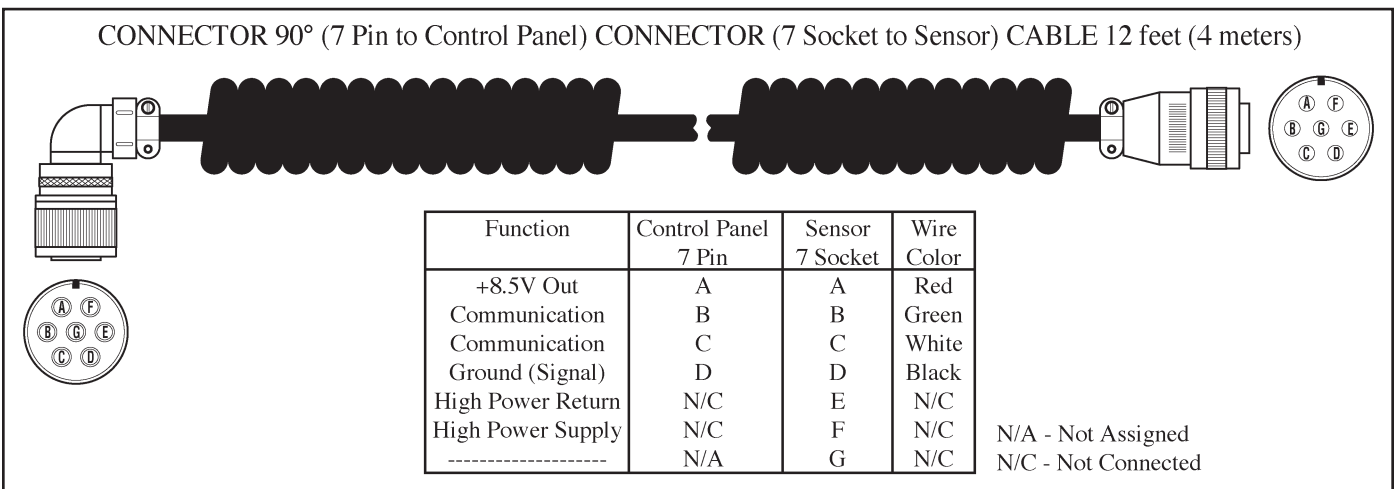

Figure 18. Sensor Cable

SYSTEMS FEATURES AND BASIC OPERATION

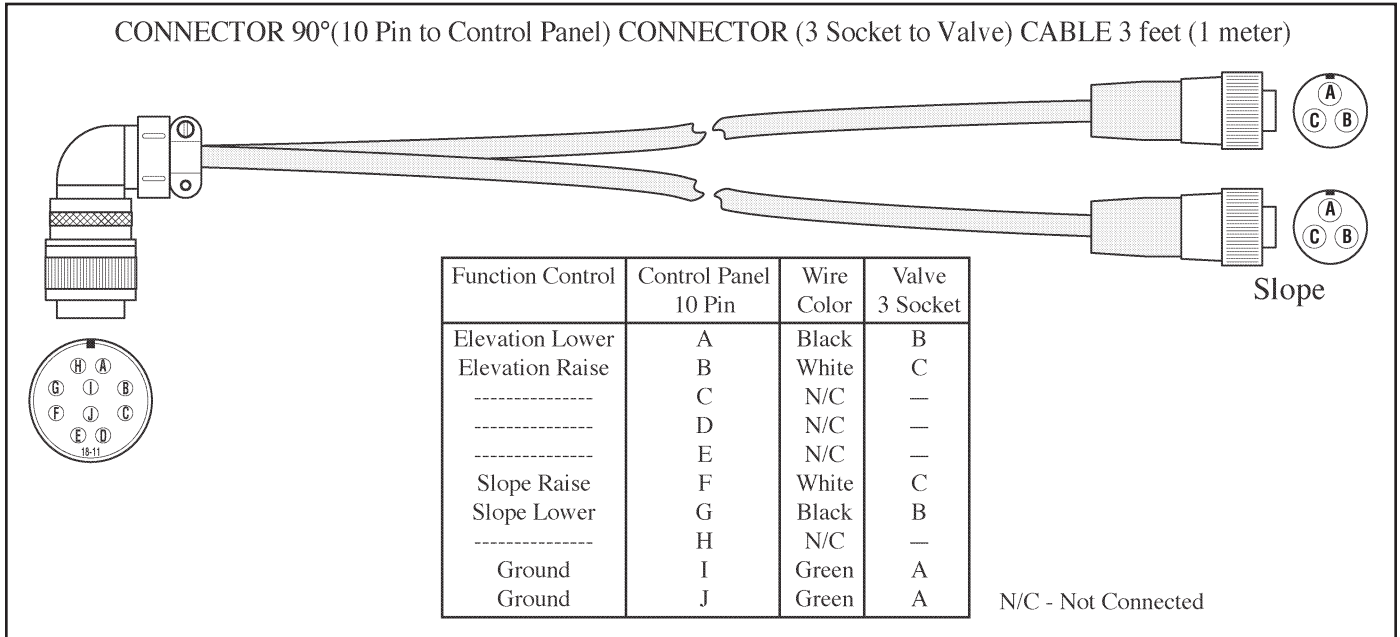

Figure 19. Valve Cable

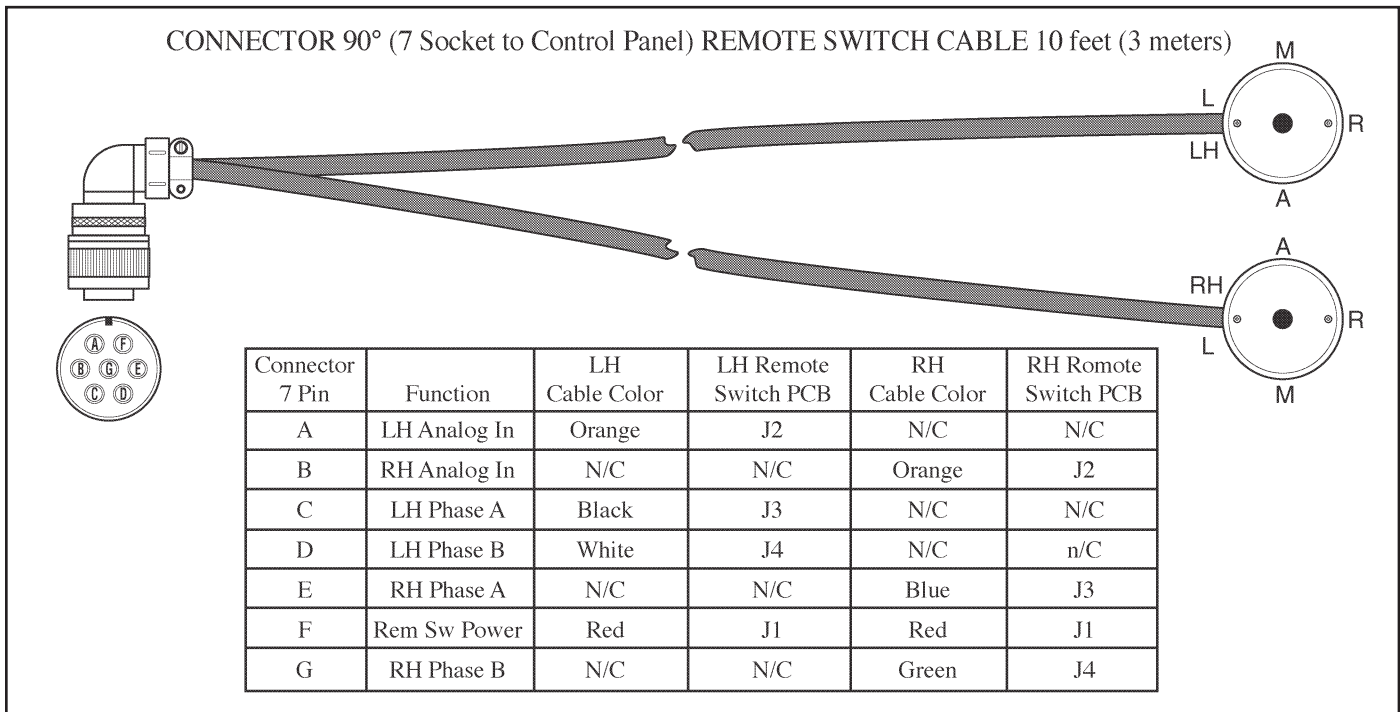

Figure 20. Remote Switches Cable

SYSTEMS FEATURES AND BASIC OPERATION

Valve Cable - communicates grade information between the Control Panel and the hydraulic valve. There is one connector for the Control Panel and two connectors for the valve. One connector goes to each valve solenoid. Labels located on the cable identify the solenoid to connect to.

Remote Switches Cable - allows operation of the Raise/Lower and Auto/Manual functions remotely (within 10 ft.) from the skid steer operator station. The cable includes two switches that mimic the two joysticks on the Control Panel. The switches should be mounted with the cable down so the direction of movement is the same as the joystick movement.

EQUIPMENT SETUP

ATI Corporation preassembles as much of the Para-Level with Slope-Tach LGB as possible. Some of the following setup procedures may already be completed. However, it is recommended that the operator be familiar with the various system components and how they interconnect.

1. Connect the Power Cable to the battery power supply. Place connector end of cable near the Control Panel bracket for later connection to the Control Panel.

NOTE: Red wire is positive and black is negative.

2. The Laser Grading Box should be positioned on a level area for attaching to the skid steer. Start the skid steer, drive up to the attachment plate and secure per the skid steer manufacturer's directions. The Level Best quick-attach plate is designed to be universal.

NOTE: If the skid steer's pins do not fit securely into the rectangular holes at the base of the attachment plate, these holes can be notched larger to accept the pins.

3. After installation, ensure that the Grading Box is level. The loader arms must be completely lowered and the bucket cylinders set so the tires of the Laser Grading Box are on the ground.

Verify that the Laser Grading Box is level by observing that the main frame is horizontal to the ground. Turn the skid steer engine OFF when connected.

4. Mount the Control Panel on the bracket attached to the hydraulic valve. Use the side knobs to secure the unit.

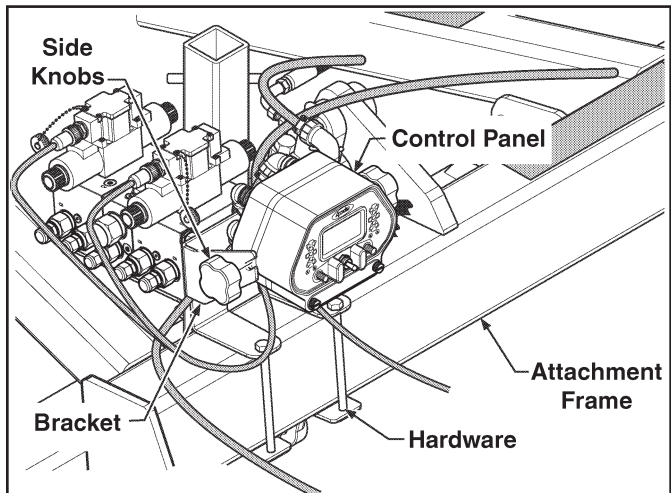

Figure 21. Control Panel Mounting

NOTE: Most skid steer's have the ability to reverse the hydraulic flow to the quick couplers. Care must be taken that the flow is always engaged the correct direction.

5. Connect the Laser Grading Box's hydraulic hoses with quick couplers to the auxiliary hydraulic ports of the skid steer. The Laser Grading Box's hydraulic manifold is marked "P" and "T" where the pressure and return (tank) hoses connect.

NOTE: "P" means pressure (supply) and "T" means tank (return). Refer to the skid steer Owner's Manual for identifying the "P" and "T" Auxiliary Hydraulic Ports.

6. Insert the two Mast Poles in the holders, one in the center and one on the right side, until they rest at the bottom of the tube. Tighten the tee handles to secure the masts. Clamp a Laser Sensor near the top of each mast so it is higher than any local obstructions including the skid steer cab or fall protection devices. (Refer to Figure 22).

SYSTEMS FEATURES AND BASIC OPERATION

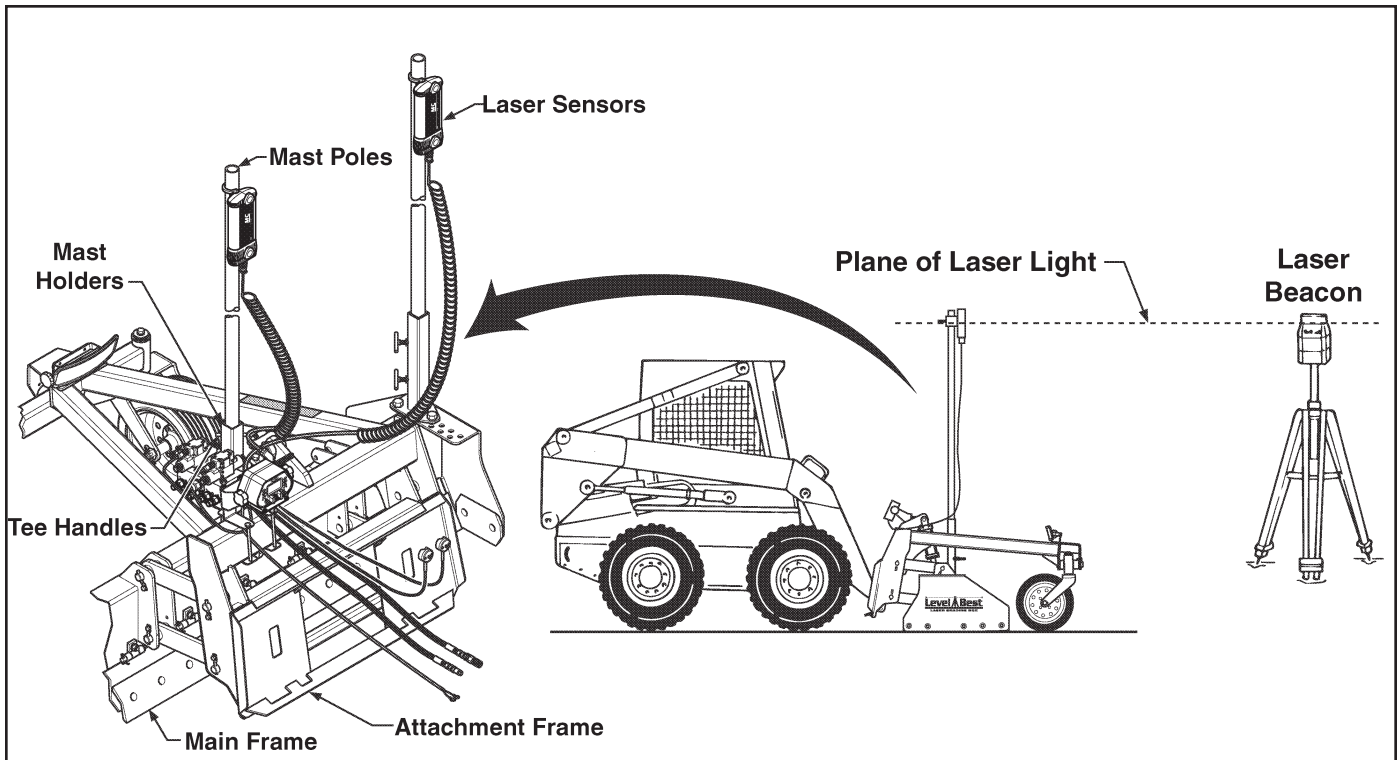

Figure 22. Components of the Automatic Control System on a Skid Steer

CAUTION

Cables must be securely fastened and pinch/rub-points eliminated. Do not fasten to hydraulic lines which may operate at high temperatures. Ensure sufficient cable length to allow movement of the machine.

7. Connect the 7-pin remote switches connector to the 7-socket connector on the Control Panel. Attach the two switches so they are accessible to the operator.

The switches are designed to mount to shafts with diameters from 3/8 to 1-1/8 in. To have the same movement as the joysticks on the Control Panel, ensure that each remote switch is mounted so the cable leading from the switch is downward. To mount a switch:

- a. Remove any dirt or oils from the mounting surface using isopropyl alcohol or appropriate cleaner.
- b. Remove the liners from the double-stick tape and apply to a remote switch. Place the switch in the desired position on the mounting surface.

- c. Place the correct length of screw for the mounting diameter through the switch and mounting surface. Secure the switch without overtightening the screws.

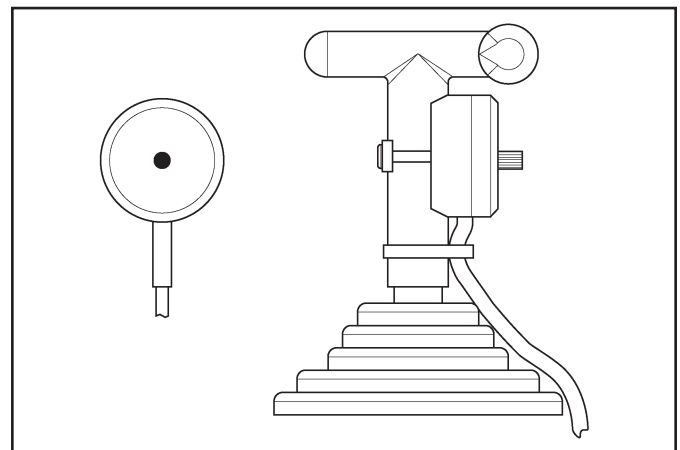

Figure 23. Remote Switch Mounting

- d. Route the switch cable along the handle and to the Control Panel. Use wire ties to prevent pinching, pulling or rubbing of the cable.
- e. Repeat the process for the other switch.
8. Connect the 90° end of the Junction Block/Receiver cable to the Control Panel. Attach the other end to the side of the Control Panel mounting bracket.

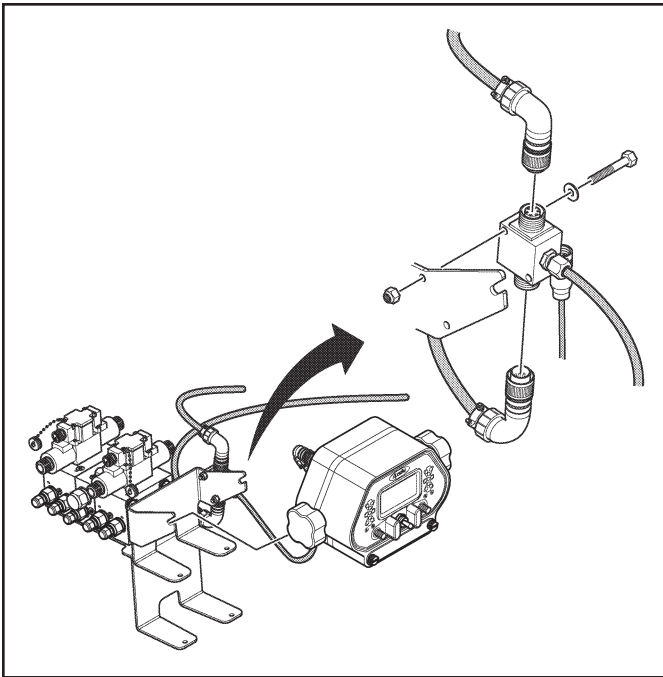

Figure 24. Junction Block and Laser Sensor Cables

9. Connect the straight end of one Sensor cable to the base of the center mast-mounted Laser Sensor and the 90° end to the Junction Block connector of the Junction Block/Receiver cable labeled L. .
10. Repeat step 9 for the other cable and Laser Sensor mounted on the right-side mast, connecting it to the Junction Block labeled R.
11. Connect the 90° end of the Valve cable to the back of the Control Panel. Connect the straight end (molded) of the Valve cable labeled SLOPE to the forward valve solenoid and the other straight end connector (not labeled) to the rearward valve solenoid.
12. Connect the 90° end of the Power Cable to the back of the Control Panel. The terminal end was previously wired to the battery.

JOB SITE SET-UP

The following are guidelines for setting up the Rotating Laser for both level job sites and sloped job sites:

- Choose a location for the Rotating Laser where obstructions, such as trees and buildings, can not block the plane of laser light. The Laser Sensor needs to be able to sense the plane of laser light at all times.

- Whenever possible, set up the Rotating Laser and the Laser Sensor at a height above the machine's cab. This prevents the cab or roll-over structure from blocking the plane of laser light as the machine moves around the job sites.
- The recommended head speed for the Automatic Control System is 20 RPS (Revolutions per Second). At 20 RPS, the Rotating Laser updates the Laser Sensor 20 times per second.

Set-Up for Level Grading

If the job site is to be level, the set-up of the Rotating Laser is simple. Since no slope is required in either axis, the Rotating Laser does not need to be aligned. The Rotating Laser will provide a level plane of laser light in all directions.

1. Locate the Rotating Laser following the guidelines above.
2. Apply power to the Rotating Laser. Level the Rotating Laser (some Rotating Lasers will automatically level, others will need manual adjustment).
3. Set the counters for both axis at 0.000% (If needed, see the Rotating Laser Operation Manual).
4. Bench the machine. See the "Benching and Operating" procedure in this section.

Set-Up for Sloped Grading

If the job site is to be graded for a single or dual slope, the Rotating Laser requires its axis to be aligned for the job site. The Rotating Laser will then provide a plane of laser light at the required slope(s).

The following procedures are for two typical examples of job sites requiring sloped grades. Remember, each job site is unique, so consider the following methods as guidelines and not as the only methods possible.

Method One:

1. Set a minimum of two grade stakes exactly in line with one of the axis to be graded.

2. Place the Rotating Laser in line with the two grade stakes.

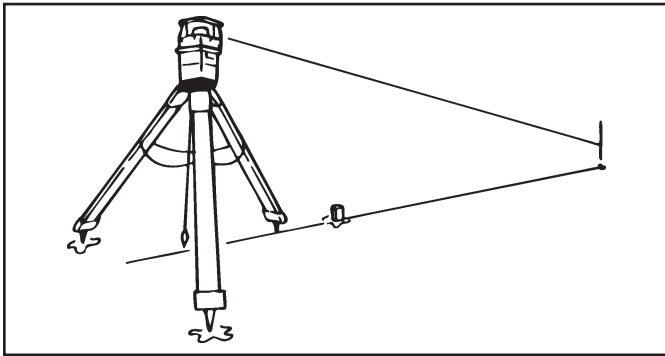

Figure 25. Method One: Align Rotating Laser with Grade Stakes

3. Switch on the Rotating Laser. Level the Rotating Laser (some Rotating Lasers will automatically level, others will need manual adjustment).
4. Set the counter on the Rotating Laser for both axis to 0.0000% (If needed, see the Rotating Laser Operation Manual).

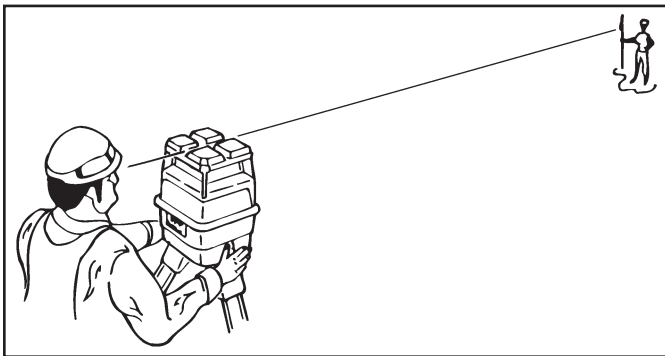

Figure 26. Sight Over Rotating Laser

5. Roughly align one of the axis to the grade stakes by sighting over the top of the Rotating Laser (Refer to Figure 26).
6. Align the plane of laser light.
 - a. Set a grade rod with Rod Eye Receiver on the far grade stake and adjust the rod until the Rod Eye Receiver indicates “On Grade.”
 - b. On the axis not aligned with the stakes, enter on the Rotating Laser: 5.000%. Allow the Rotating Laser to level itself to this new position, if needed.
 - c. Check the Rod Eye Receiver again.

- If the Rod Eye Receiver indicates “On Grade”, the plane of laser light is aligned correctly.
- If the Rod Eye Receiver indicates the plane of laser light is too high or too low, have a second person rotate the Rotating Laser on the tripod in small steps until the Rod Eye Receiver indicates “On Grade.”

7. Enter on the Rotating Laser the required percent of grade for each axis and allow the Rotating Laser to level itself again.
8. Bench the machine. See the “Benching and Operating Your Machine” procedure in this section.

Method Two:

NOTE: This procedure requires that the elevations of the grade stakes are correct and aligned to the slope or percent of grade required.

1. Set a minimum of two surveyed grade stakes. The stakes must have elevation information.

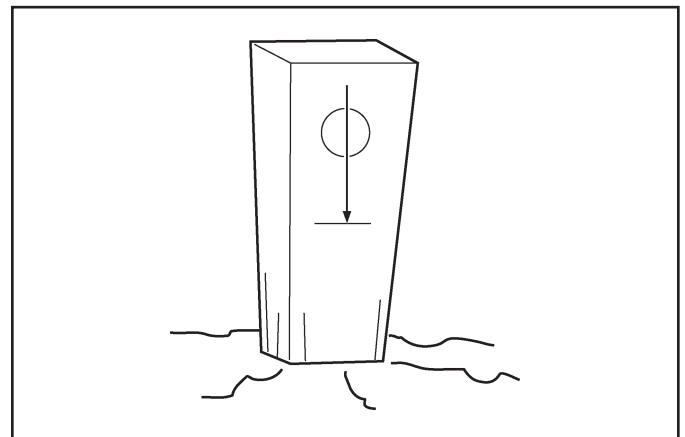

Figure 27. Grade Stake with Elevation Mark

2. Place the Rotating Laser a few feet (meters) behind the first grade stake and in line with one of the far grade stakes (it is not critical to align the Rotating Laser exactly). (Refer to Figure 28.)

NOTE: Follow the guidelines at the beginning of this section when placing the Rotating Laser.

3. Switch on the Rotating Laser. Level the Rotating Laser.
4. Roughly align one of the axis to the grade stakes by sighting over the top of the Rotating Laser (Refer to Figure 26).
5. Set both the counters on the Rotating Laser to the required percent of grade (If needed, see the Rotating Laser Operation Manual).

7. Align the plane of laser light.
 - a. Align the bottom of a Grade Rod to the mark on the far grade stake.
 - b. Check the Rod Eye Receiver.
 - If the Rod Eye Receiver indicates “On Grade,” the plane of laser light is aligned at the correct slope.
 - If the Rod Eye Receiver indicates the plane of laser light is too high or too low, have a second person rotate the Rotating Laser on the tripod in small steps until the Rod Eye Receiver indicates “On Grade.”

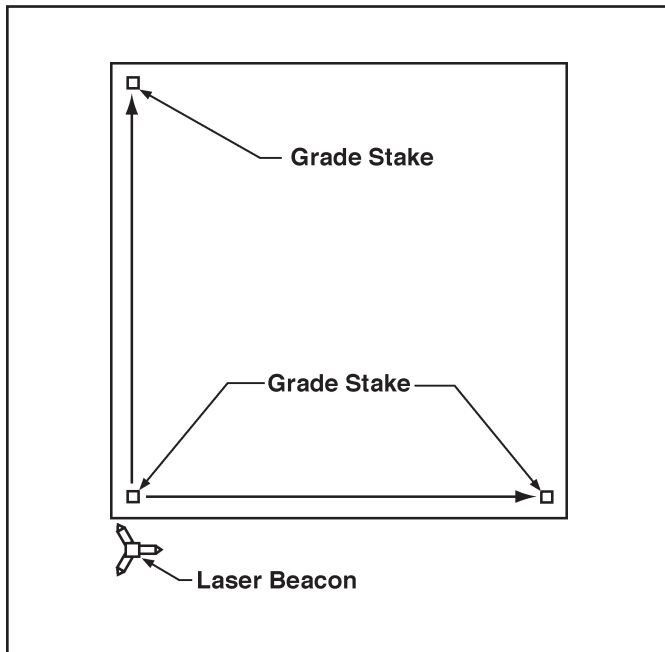

Figure 28. Method Two: Align Rotating Laser with Grade Stakes

NOTE: The Grade Rod must be held plumb for each of the readings taken in the following steps.

6. Establish the H.I. (height of the instrument) for the plane of laser light.
 - a. Align the bottom of the Grade Rod to the mark on the near grade stake.
 - b. Adjust the Rod Eye Receiver up and down until it indicates “On Grade.”
 - c. Adjust the Rod Eye Receiver for any cut or fill amount indicated by the grade stake.
 - If the grade stake shows a cut, extend the Grade Rod and Rod Eye by the amount shown as a cut.
 - If the grade stake shows a fill, lower the Rod Eye by the amount shown as fill.

NOTE: If it was necessary to rotate the Rotating Laser a significant amount at the far stake, then the original reading at the near stake may be out of tolerance. Check the setting again and make minor adjustments as required.

8. Bench the machine.

NOTE: If needed, check the elevations on both the plane of laser light and the grade stake elevations by setting the bottom of the Grade Rod at any stake’s grade mark and checking the Rod Eye Receiver for the “On Grade” indication.

BENCHING AND OPERATING

Before benching, the plane of laser light must be set at its proper slope. Benching is the process of setting the relationship between the Laser Sensor and the Rotating Laser or benchmark. Failure to properly bench the system before grading will result in an unacceptable grade.

The goal is to have the Laser Grading Box approximately 1/2 full during operation. If, during rough grading, a lot of material needs to be removed from a site, the elevation offset feature can be used to rough-in the grade. As material is removed, the elevation offset can be reduced and the site regraded. This may need to be repeated several times until finished grade is achieved.

Benching

NOTE: Finish grade can be checked several times during the grade process to “zero” in on final grade.

1. Turn the system on using the Power switch.
2. Ensure the system is in manual control and dual elevation mode (default).
3. Turn the Rotating Laser ON and set to 0.0% slope.

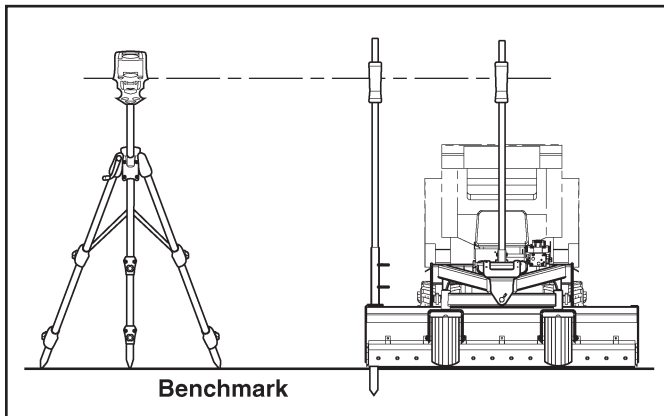

Figure 29. Benching the Para-Level LGB with a Level Plane

4. Move the machine to an area to be graded. Using the system controls, lower the cutting edge to finished grade. This is normally done close to the Rotating Laser.

NOTE: If necessary, a small area may need to be manually graded to obtain sufficient space for benching.

5. Use a bubble level to level the LGB. Re-check the cutting edge to ensure it remains at the finished grade.
6. Raise the Power switch and hold in the I position for 1 second to access the User Setup menu.
7. From the User Setup screen on the Control Panel, highlight the Deadband (Accuracy) icon and press the joystick.
8. Select an appropriate deadband for the job and conditions.
9. Press the joystick twice to exit the deadband setup.

10. Adjust the height of each Laser Sensor until the appropriate center Grade Position LED cluster is lit, indicating it is “on grade.” Tighten the mounting knobs on each Laser Sensor securely after adjustment.

For grading to level, skip to step 14. For grading on a slope, continue from step 11.

11. For sloped grades, the Rotating Beacon can now be adjusted to the proper slope.
12. With the LGB remaining at finished grade, raise or lower the Rotating Beacon on the tripod until the Laser Sensor on the center mast indicates the Elevation is “on grade.”

! WARNING

Always have system in Manual setting when not operating the skid steer.

13. Using all applicable safety precautions, set the Control Panel to automatic control. Drive the skid steer a short distance to allow the control system to adjust the LGB to the grade.
14. Both elevations should now indicate 0.0. Slope offset and other adjustments for rough grading can be made and grading can begin.
15. After grading a small area, check the grade using a grade rod. If required, adjust the LGB using this procedure.

NOTE: Most materials graded must later be compacted. To compensate for the compacting distance, raise the Rotating Beacon. This raises the cutting edge by the same distance. The distance the Rotating Beacon is raised depends on the material.

Benching with a Rod Eye

To bench the Laser Sensor follow the process listed below:

1. Turn on the Rotating Beacon. Attach a Rod Eye to a measuring pole and turn on. Set the base of the measuring pole on the benchmark and adjust the measuring pole so the Rod Eye emits a solid “On Grade” tone (compensate for slab thickness and compaction if needed).

2. Find an area to be graded that is close to specified grade. Making sure the control system is in manual mode, start the skid steer, engage the auxiliary hydraulics and move the unit to that location. Manually raise or lower the Laser Grading Box's cutting edge until it is even with the bottom of the measuring pole when the Rod Eye is emitting the "On Grade" tone or resting on the ground if already at grade.

NOTE: The elevation measurement must be made as close to the Laser Sensor as possible, i.e., in the middle or on the right-side.

3. With the control system deadband set as required for the job, move the Laser Sensor to a height on the mast pole where it indicates the beam in the "On Grade" position and is unobstructed by any object.

NOTE: Operator may prefer to turn the face of the Laser Sensor towards the operator for easy viewing.

4. Move the Rod Eye to the right side of the blade. Using the tilt function (right-side joystick), manually raise or lower the Laser Grading Box's cutting edge until it is even with the bottom of the measuring pole while the Rod Eye is emitting the "On Grade" tone or resting on the ground if already on grade. Repeat step 3.

Operation

After the Laser Grading Box is connected and the Automatic Control System is calibrated, operation can begin.

The operational goal is to drive over the area to be graded with the box 1/2 full of material and the green LEDs on the grade indicators always illuminated.

1. When seated in the Operator's seat, start the skid steer. Turn the control system on and set the system to automatic control. For initial or rough-cut situations, use a higher deadband setting.

NOTE: Most materials graded must later be compacted. To compensate for the compacting distance, raise the Rotating Beacon. This raises the cutting edge by the same distance. The distance the Rotating Beacon is raised depends on the material.

2. Drive the machine forward or reverse (the Para-Level Laser Grading Box has front and rear cutting edges). The Automatic Control System constantly senses the plane of laser light to maintain the cutting edge of the box at the required elevation. Note the following during operation:

- In some situations, the Automatic Control System may require a cut deeper than the machine can handle. The machine may lose traction, stall the engine, or the wheel frame will be lifted off the ground to the maximum stroke of the cylinder as the cutting edge tries to reach finished grade. If this occurs, set the system to manual control and use the joysticks to raise the cutting edge until the machine can move the material. Make multiple passes to cut the area closer to finished grade and then go back to automatic control. This allows the high spots to be gradually removed.
- If one of the Control Panel or Laser Sensor grade lights are blinking, it indicates the direction of the last elevation prior to passing out of the laser beam. If necessary, do the rough grading and then bench the Laser Grading Box again.

NOTE: In rough grading situations, use the Automatic Control System as an "Indicate Only" system and operate the machine under manual control. After the area has been rough graded, switch to automatic control.

WARNING

Always have system in Manual setting when not operating the skid steer.

-
4. After several passes with the Laser Grading Box, stop and turn off the skid steer. Place the base of the measuring pole on the graded area and check grade elevation.
 5. After a rough grade is achieved, the Deadband (Accuracy) may be changed to a narrower setting as required to meet the job tolerance requirements. With a tighter deadband, the speed of the skid steer needs to be decreased for optimum finish.

TROUBLESHOOTING

SYMPTOM	POTENTIAL CAUSE	REMEDY
Control Panel lamps do not light.	<p>Control Panel not turned on.</p> <p>Power Cable not connected to Control Panel.</p> <p>Power Cable not providing power to the Control Panel.</p> <p>Fuse blown.</p> <p>Electrical short.</p>	<p>Push the Power ON/OFF Switch.</p> <p>Connect power cable to Control Panel.</p> <p>Check that the Power Cable is connected to the battery. The red wire connects to the positive (+) post and the black wire connects to the negative (-) post.</p> <p>Remove the Power Cable from the Control Panel and, using a volt meter, check for a minimum of 11 volts DC.</p> <p>Check the fuse.</p> <p>Disconnect all cables except the Power Cable. If the lamps still do not cycle when the Control Panel is turned on, contact the local Apache Technologies dealer.</p>
Laser Sensor does not display grade.	<p>No Rotating Laser in range.</p> <p>Laser beam blocked.</p> <p>Electrical short.</p>	<p>Ensure Laser Sensor is within operating range of Rotating Laser.</p> <p>Ensure beam is striking middle of the Laser Sensor</p> <p>Check and clean glass covering the Laser Sensor's photo cells.</p> <p>Check for obstructions keeping Laser Sensor from seeing the Rotating Laser.</p> <p>If LEDs do not cycle when Control Panel is turned On, contact the local Apache Technologies dealer.</p>

TROUBLESHOOTING

SYMPTOM	POTENTIAL CAUSE	REMEDY
Laser Sensor does not display grade (cont)	Laser Sensor not receiving power.	<p>Check Fuse in the Control Panel.</p> <p>Check Sensor Cable for damage. Use an Ohm meter to check continuity.</p> <p>Disconnect and reconnect the Laser Sensor Cable making sure the connectors on the ends are seated into the Laser Sensor and Junction Block/Receiver Cable correctly.</p> <p>Check that the Control Panel is communicating with the Laser Sensor, indicated by the Control Source Indicator icon on the LCD.</p>
Box has trouble staying on grade.	<p>Rotating Laser out of range.</p> <p>Laser beam being reflected.</p> <p>Multiple laser beams.</p> <p>Laser deadband set too narrow.</p> <p>Travel speed is too fast for grade tolerance.</p> <p>Hydraulic response too quick.</p> <p>Hydraulic flow reversed.</p>	<p>Ensure Laser Sensor is within specified operating range of Rotating Laser.</p> <p>Ensure Rotating Laser's light is not reflecting off other surfaces (windows, windshields, mirrors, etc.) causing multiple readings by the Laser Sensor.</p> <p>Ensure that there are no other lasers operating on the job site or nearby.</p> <p>Ensure the Deadband (Accuracy) setting is appropriate for rough grading.</p> <p>Slow down.</p> <p>Decrease the Valve Speed setting.</p> <p>Confirm the pressure is going in the "P" port.</p>

TROUBLESHOOTING

SYMPTOM	POTENTIAL CAUSE	REMEDY
Laser Grading Box does not raise or lower.	Control Panel not turned on.	Push the Power switch.
	No hydraulic flow to Laser Grading Box.	<p>Ensure hydraulic control handle of skid steer is in correct position.</p> <p>Ensure auxiliary hydraulics are ON or in continuous flow mode.</p>
	Cables not connected correctly.	<p>Check Valve cable, valve and valve solenoids for visible damage.</p> <p>Move directional valve spool manually using the overrides on the end of the directional valve.</p>
		<div style="border: 1px solid black; padding: 5px; background-color: #e0e0e0;"> <p> WARNING</p> </div> <p>Be sure to stay clear of any moving parts of the Laser Grading Box.</p> <p>If the Laser Grading Box moves, refer to Electrical problems. If the Laser Grading Box does not move, refer to Hydraulic problems.</p>
	Electrical Problems	<p>Check Valve cable, valve and valve solenoids for visible damage.</p> <p>Use an Ohm meter to check cable for continuity.</p>
	Hydraulic Problems	<p>Confirm hydraulic flow through the manifold and returning to the power source through the “T” hose.</p> <p>Contact ATI Corporation for help troubleshooting the hydraulic manifold.</p>
Laser Grading Box moves in opposite direction.	Hydraulic flow reversed.	<p>Confirm the pressure is going in the “P” port.</p> <p>Verify control handle is moving in desired direction.</p>

SPECIFICATIONS AND MAINTENANCE

SPECIFICATIONS

Dimensions

Model	PL72	PL84	PL96
Box Width	72 in. (183 cm)	84 in. (213 cm)	96 in. (244 cm)
Overall Width	74.8 in. (190 cm)	86.8 in. (220 cm)	98.8 in. (251 cm)
Total Length	75 in. (191 cm)		
Box Capacity, Front	11.5 ft ³ (0.33 m ³)	13.4 ft ³ (0.38 m ³)	15.3 ft ³ (0.43 m ³)
Box Capacity, Rear	7.0 ft ³ (0.20 m ³)	8.0 ft ³ (0.23 m ³)	9.0 ft ³ (0.25 m ³)
Weight	1970 lbs. (895 kg)	2030 lbs. (923 kg)	2090 lbs. (950 kg)

Control Panel CB52

Main Display.....LCD
 On-Grade LED'sGreen
 High/Low LED'sRed
 Operating Voltage 10 to 30 Volts DC, reverse polarity protected
 Electrical ConnectionStandard military type
 Valve CompatibilityProportional Time (On/Off), Proportional Current, and Proportional Voltage
 Maximum Current5 Amps per driver
 Remote SwitchTwo; Raise/Lower, Auto/Manual multi-direction
 Deadband Range0 to 2.0 in. (0 to 50 mm)
 Weight5 lbs. (2.25 kg)
 Dimensions7.0 x 5.5 x 5.5 in. (178 x 140 x 140 mm)
 Operating Temperature-4 to 140° F (-20 to 60° C)

Laser Sensor BULLSEYE 5MC

Beam Reception360°
 Operating Range2000 ft. (610 m) radius, laser dependent
 Laser RPMMinimum - 105 ; Maximum - 1200
 Vertical Reception6.75 in. (170 mm)
 AccuracySet at Control Box
 PowerSupplied by Control Panel
 LED DisplayMini display for set-up Red - Hi, Low, On Grade
 Out of Beam IndicationHigh and Low
 Dimensions (LxWxD).....13.50 x 5.58 x 5.88 in. (343 x 142 x 149 mm)
 Mounting Pipe.....1.66 to 2.00 in. O.D. round tube (42 to 50 mm) and 1-1/2 in. (38 mm) square tube
 Operating Temperature-4 to 140° F (-20 to 60° C)

SPECIFICATIONS AND MAINTENANCE

MAINTENANCE

The rugged and durable Automatic Control System is built to last, but as with all equipment, a few minutes of routine care, maintenance, and cleaning can extend the life of the system.

Storage and Transport

Most often the Laser Grading Box and its hydraulic controls remain on the machine. However, the Control Panel, Laser Sensor, Coiled Sensor Cable and Solenoid Cable should be stored in a safe, protected place when not in use. Protect the cable connections by installing the covers supplied.

Cleaning

The Laser Sensor is completely sealed and purged with dry nitrogen. It requires no maintenance other than periodic checking to be sure its mounting structure is tight and secure.

The Control Panel is water-resistant. It can be cleaned with mild soap, water, and a damp, soft cloth. Do not submerge the Control Panel or direct high pressure spray at it. Do not use a dry cloth to wipe the Laser Sensor or Control Panel as scratching may occur.

Cables and Hoses

Check all cables and hoses regularly for signs of wear and damage. Keep cable connections clean and free from dirt and corrosion. If a cable has been damaged, do not attempt to repair. Incorrect or poor connections can cause damage to your Automatic Control System.

When applicable, check the hydraulic hoses. Look for areas where the hoses could rub against each other or another object as they expand and contract under pressure. Check the hydraulic fittings for tightness.

Machine

Check areas that affect the Automatic Control system function and accuracy, such as looseness or play in the cylinders or wear on the box's cutting edge. Looseness in the connection to the tractor/skid steer, such as in the adaptor plate/3-point hitch, will cause inaccurate depth positioning.

Also check the tractor/skid steer routinely for wear to its components, such as loader pins and 3-point linkage, ensuring it is operating properly.

Calibration

Perform periodic calibration checks of the Rotating Laser System as outlined in its Operation Manual to ensure accurate performance.

SERVICE

If the Automatic Control System is not functioning properly, the first step is to determine the problem component. Use the Troubleshooting Chart to determine possible causes and remedies. The following test equipment is needed:

- Voltage/Ohm Meter
- Rotating Laser or Laser Simulator

Use the Cable Wiring Diagrams on Pages 12 and 13 to troubleshoot electrical problems.

The Control Panel provides diagnostic codes to aid in troubleshooting and diagnostics. If a 5-digit code appears, contact ATI Corporation for assistance in diagnosing the code.

If the code 1505 appears, it indicates communication with the laser receiver(s) has been lost. Check the cable connections.

CAUTION

To prevent serious damage to the Automatic Control System, never replace a fuse with a fuse that has a higher amperage value.

CAUTION

The Automatic Control System is a highly sophisticated electronic system. Do not attempt repairs to the components. Contact Apache Technologies, Inc. or your local dealer if you have any problems.

SPECIFICATIONS AND MAINTENANCE

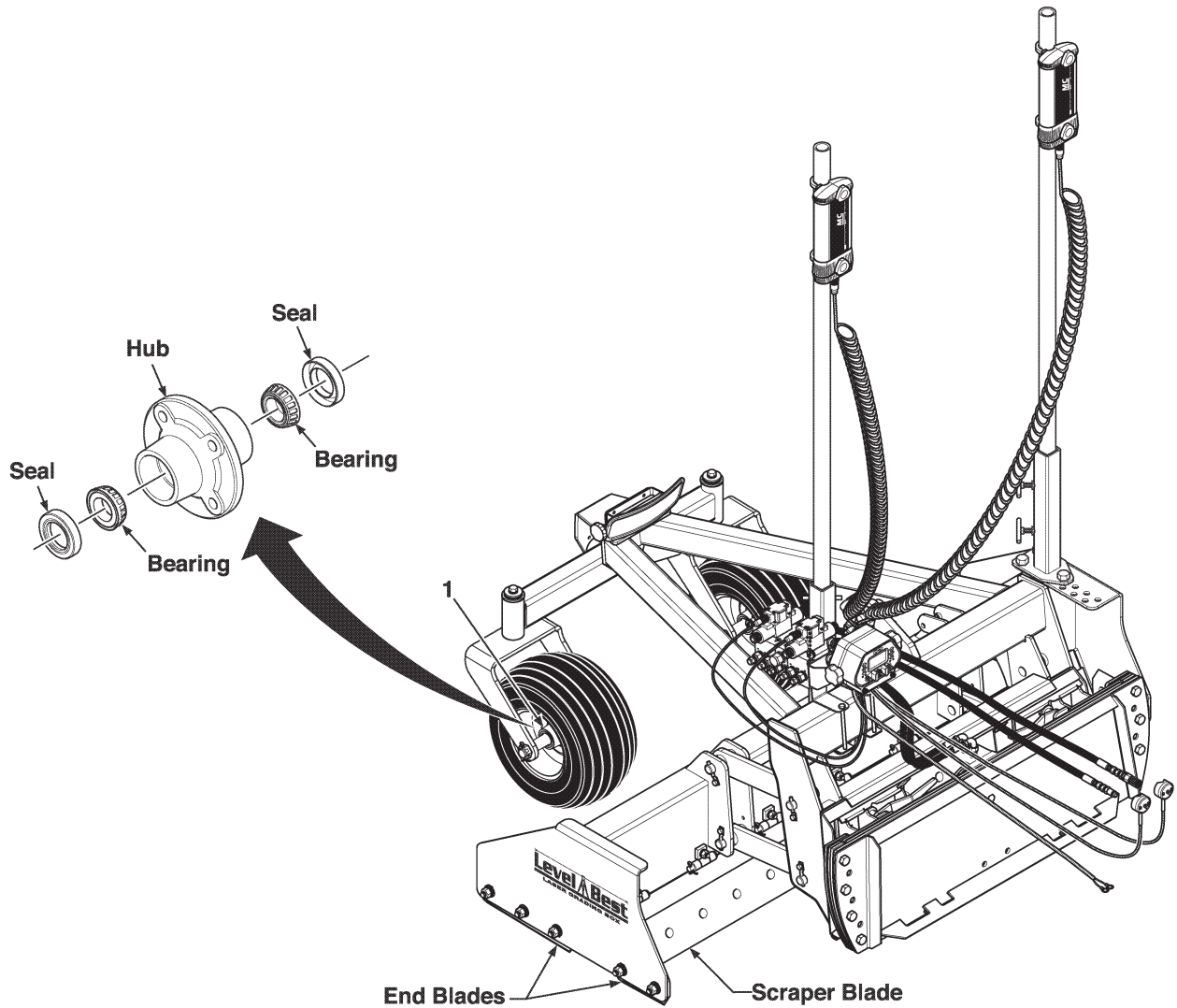

ITEM	NAME	FREQUENCY	LUBE TYPE
1.	Wheel Hub (2)**	Annually	EP*
<p>* EP - Multi-Purpose Grease.</p> <p>** Bearings must be pulled apart cleaned and packed once a year. Inspect grease seals and replace if necessary.</p>			

NOTES:

1. Check Hydraulic System Components for wear and/or leaks.
2. Check and tighten all bolts and nuts for scraper blade and end blades, weekly.

Figure 30. Lube and Maintenance Chart

REGISTRATION CARD

By buying this product, you, the purchaser of this product, agree to the following:

To the fullest extent permitted by law, the purchaser of this product shall indemnify and hold harmless ATI Corporation and its authorized dealer from and against claims, damages, losses and expenses, including but not limited to attorney's fees, arising out of or resulting from the use of the product, provided that such claim, damage, loss or expense is attributable to bodily injury, sickness, disease or death, or to injury to or destruction of tangible property, but only to the extent caused by the negligent acts or omissions (Including but not limited to misuse or alteration of the product) of the purchaser, anyone directly or indirectly employed by the purchaser or anyone for whose acts the purchaser may be liable, regardless of whether or not such claim, damage, loss or expense is caused in part by a party indemnified hereunder.

In claims against any person or entity indemnified under this agreement by an employee of the purchaser, anyone directly or indirectly employed by the purchaser or anyone for whose acts the purchaser may be liable, the indemnification obligations shall not be limited by a limitation on amount or type of damages, compensation or benefits payable by or for the purchaser under worker's compensation acts, disability benefit acts or other employee benefit acts.

CUSTOMER COPY

Dealer _____ Date Installed _____
Grading Box Model # _____ Serial # _____
Control Panel Model # _____ Serial # _____
Laser Sensor Model # _____ Serial # _____
Dealer Name _____
Street _____
City, State, Zip _____
Telephone _____ Fax _____
Signature _____

DETACH AND MAIL TO ATI CORPORATION • 250 EARLAND DRIVE • NEW HOLLAND, PA 17557
or FAX to (717) 354-2162



MANUFACTURER'S COPY

Dealer _____ Date Installed _____
Grading Box Model # _____ Serial # _____
Control Panel Model # _____ Serial # _____
Laser Sensor Model # _____ Serial # _____
Customer Name _____
Street _____
City, State, Zip _____
Telephone _____ Fax _____
Signature _____